

Amplifier

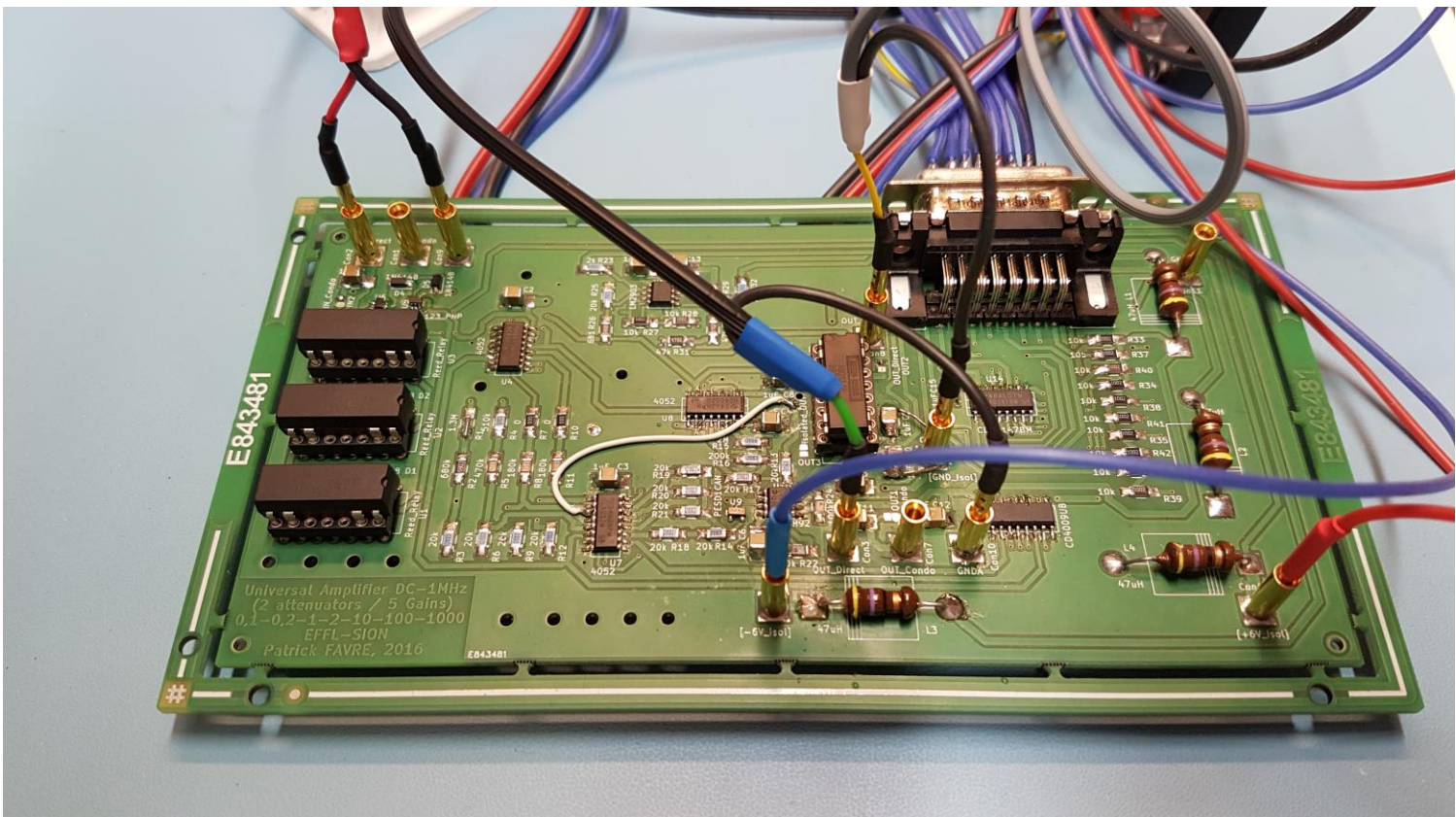

Printed circuit board



Features

Selector	Gain	Attenuation	Av ampli 1	Av ampli 2	f0	Ui max pour Us=6Vpp	
7	1000		100	10	100 kHz	6 mV pp	
6	100		10	10	1 MHz	60 mV pp	
5	10		1	10	1 MHz	600 mV pp	
4	2	(:5):10	2	10	1 MHz	3 V pp	
3	1	:10	1	10	1 MHz	6 V pp	IN bypass
2	0.2	:50	1	10	1 MHz	30 V pp	
1	0.1	:100	1	10	1 MHz	60 V pp	

Synoptic Plan

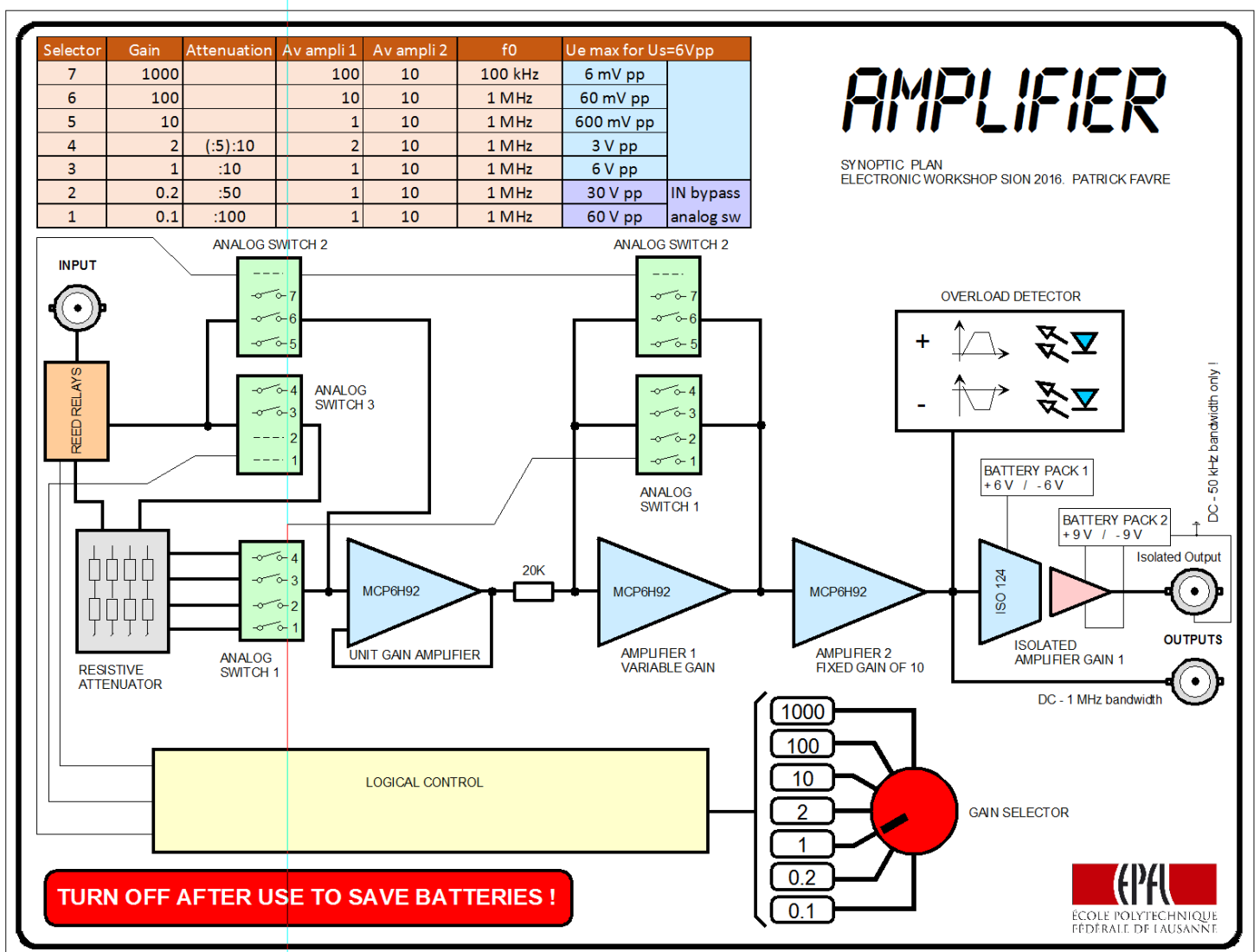

Battery case made by 3D printer

