



ÉCOLE POLYTECHNIQUE  
FÉDÉRALE DE LAUSANNE

# Calibration of $RuO_2$ commercially available resistors for temperature sensing at dilution fridge temperatures

## TP IV Report

Supervised by:

**Professor Henrik Ronnow**

and

**Julian Piatek**

Laboratory for quantum magnetism (LQM)

Faculté des Sciences de base  
de

l'Ecole Polytechnique Fédérale de Lausanne (EPFL)

Presented by

**Pau Jorba**

Master Student in Physics Engineering  
at the EPFL

LAUSANNE  
2013

# Contents

<b>1</b>	<b>Introduction</b>	<b>2</b>
1.1	Dilution refrigerator . . . . .	2
1.2	$RuO_2$ resistors . . . . .	4
1.3	SRD and CMN thermometers . . . . .	5
<b>2</b>	<b>Experimental details</b>	<b>7</b>
2.1	Thermometers design . . . . .	7
2.2	Temperature scans . . . . .	10
<b>3</b>	<b>Calibration and discussions</b>	<b>11</b>
3.1	Calibration . . . . .	11
3.2	Very low temperature range . . . . .	15
3.3	Reproducibility . . . . .	16
3.3.1	Within the same thermometer . . . . .	16
3.3.2	Within the batch . . . . .	17
	<b>Conclusion</b>	<b>18</b>
	<b>Bibliography</b>	<b>19</b>

# Chapter 1

## Introduction

### 1.1 Dilution refrigerator

To understand fundamental interactions in different systems, we have to be able to measure on materials in a range of temperatures where the thermal energy is considerably lower than the energy of these interactions. There are different techniques to achieve low temperatures, in this report we are interested in the Dilution Refrigerator (DR). The advantage of a DR compared to other techniques is that we can achieve very low temperatures (around  $5mK$ ) in a continuous operation. Other techniques provide either, higher minimum temperatures, or *one shot* measurements.

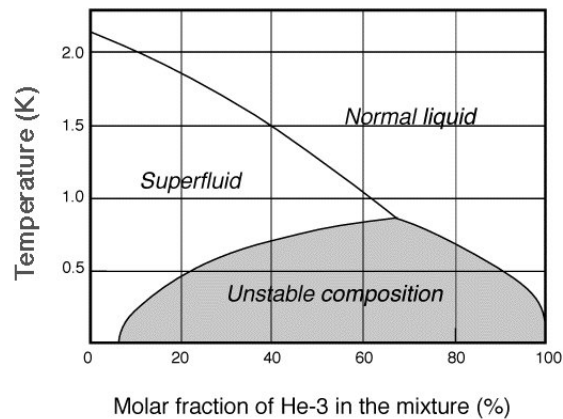

Figure 1.1: Phase diagram for the mixture of helium isotopes,  ${}^3\text{He}$  and  ${}^4\text{He}$ , at saturated vapor pressure [1].

The DR is based on utilizing the unique properties of mixtures of helium 3 ( ${}^3\text{He}$  boiling point:  $3.19K$ ) and helium 4 ( ${}^4\text{He}$  boiling point:  $4.2K$ ). In the figure 1.1, one can see that below certain temperature there is a unstable phase. In the mixing chamber, where the lowest temperature is achieved, there are two phases coexisting, one which is very rich in  ${}^3\text{He}$  (bottom right of the figure) and one which is mainly superfluid  ${}^4\text{He}$  (bottom left of the figure). The concentrated phase (rich in  ${}^3\text{He}$ ) is lighter than the other one and stays on the top. Taking a  ${}^3\text{He}$  atom from the concentrated phase to the superfluid phase is an endothermic process.

Since this phase separation exists at any temperature we are theoretically always able to remove heat from the medium. By pumping the  $^3\text{He}$  through the superfluid  $^4\text{He}$  we may maintain the low concentration of  $^3\text{He}$  in the  $^4\text{He}$  phase. [2].

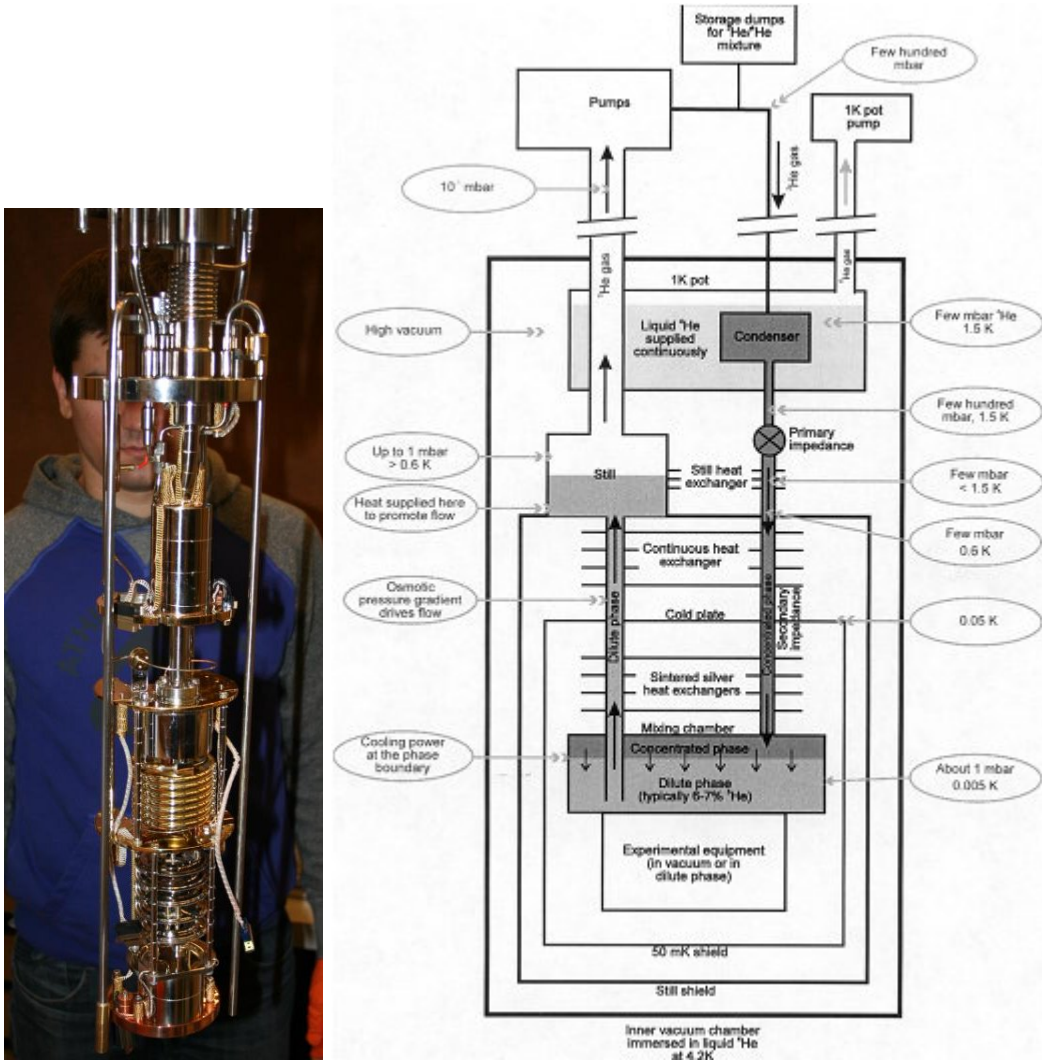

Figure 1.2: Picture of the inner part of our DR taken in the LQM lab (left). Schematic diagram of a dilution refrigerator (right) (taken from [3]).

In the figure 1.2, we present a picture and a Schematic of the fridge. The whole process is quite sophisticated, there are many commercially available dilution refrigerators in different configurations. In our case, the refrigerator is a Kelvinox 400 from Oxford instruments (Fig. 1.2), and it is operated inside a cryostat (also from Oxford) filled with liquid  $^4\text{He}$ . The cold part of the fridge ( $<4\text{K}$ ) is in the inner vacuum chamber (IVC) which is in contact with the liquid helium of the cryostat. The top part of the fridge consists in a 1K pot which evaporates liquid helium taken from the cryostat, by pumping on it we can get down to temperatures close to  $1.5\text{K}$ . The mixture enters the fridge through the condensing line and is well thermalised with the 1K pot. It is then driven down, through heat exchangers for further cooling, to the mixing chamber (MC) where the cooling process takes place with the phase

separation mentioned above. Osmotic gradient pressure drives the flow of the dilute phase up through the heat exchanger and into the still where it is pumped. The circuit is closed, so once the mixture is pumped from the still, it is driven back to the condensing line. There is a gradient of temperature from the top of the IVC ( $4.2K$ ) to the bottom (base temperature around  $7mK$ ), it is then important to have a proper insulation. The IVC is in high vacuum and there is a radiation shield thermalised to the cold plate ( $50mK$  at base temperature) protecting the MC plate and the sample space from the black body radiation of the IVC walls.

The cooling power and the base temperature are directly related to the flow of the  $^3He$  through the system. To improve it, it is important to have a powerful pump that it is able to pump the mixture at a high rate. It is also why we use the heat exchangers within the incoming and outgoing lines, on one hand we cool down the warm mixture coming in, and, on the other hand, we warm up the cold mixture coming out to make it easier to evaporate it. There is also a heater in the still to help the evaporation of the mixture if it is needed. Finally it is also important to ensure that there will be no contamination gases entering the fridge as they would freeze and block the lines. To avoid contamination, the mixture passes through liquid Nitrogen and liquid helium cold traps before entering the condensing line.

## 1.2 $RuO_2$ resistors

$RuO_2$ -based resistors have been the *defacto* thermometers material for sub Kelvin measurements. They are, for the last 30 or 50 years, widely used in electronics because of their good resistance stability at room temperature (*i.e.* a low temperature coefficient of resistance), and their long term stability. They are also interesting due to their simple preparation and their small size. What makes them more interesting for low temperature measurements is that they have a high temperature sensitivity below liquid helium temperatures (Fig. 1.3). By calibrating them we can relate the resistance to the temperature with a very good accuracy [4]. Moreover they show a smaller magnetoresistance (*i.e.* changes in the resistance due to the magnetic field) than other low temperature thermometers [5], which is an interesting feature for quantum magnetism measurements.

It is also important to ensure their reproducibility. When we do temperature cycling from room temperature to low temperatures on the thermometers, they undergo strong mechanical strains that modify their low-T resistance. To avoid that it is useful to precycle the thermometers to low temperatures many times before the calibration. It is known that after a hundred cycles to liquid nitrogen temperatures ( $77 K$ ) the thermometers become stable, all the mechanical strains have been released [6].

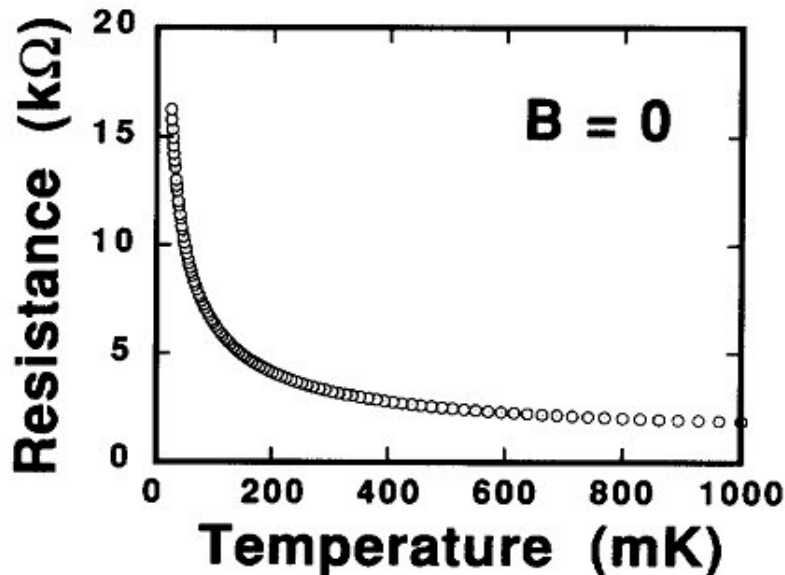

Figure 1.3: Resistance as function of temperature from 25 mK to 1 K of a  $RuO_2$ -based thermometers [6].

### 1.3 SRD and CMN thermometers

The commercially available resistors have a nominal resistance at room temperature, but all of them will have a differing behavior at low temperature, it is why we have to calibrate each of them. To do this, we need to compare the resistance of the resistors with a known temperature with a good precision. For that we could use the MC thermometer, a high quality resistor. The problem is that it was not calibrated, we used a standard calibration, giving an error of  $30mK$  at base temperature ( $8mK$ ). We would add our calibration errors to the errors in the calibration of the MC thermometer, giving a low quality final calibration. We can have a better measure of the temperature in the MC using simultaneously a superconductive reference device (SRD) and a cerium magnesium nitrate thermometer (CMN). The CMN thermometer is based on the behavior of a typical paramagnetic salt at low temperature [7]. The susceptibility of the CMN is proportional to  $1/T$ , its signal follows the "Curie-Weiss" law plus a background term  $B$  as shown in the equation (1.1). Here  $C$  is a constant specific to the material,  $T$  is the temperature in Kelvins, and  $T_{CU}$  is the Curie temperature.

$$\chi = \frac{C}{T - T_{CU}} + B \quad (1.1)$$

This gives an almost continuous measure of the temperature in the range of  $8mK$  to about  $8K$ . The problem is that the constants of the equation (1.1) are very sensitive to the different conditions and have to be calibrated at each measurement. Moreover we change the amplification factor of the preamp used to read the temperature depending on the temperature scale that we are measuring. It is why we also monitor the signal of the SDR, it is a sensor that has 13 stable temperature reference points between approximately  $15mK$  and  $7.2K$ . The points are the superconductive transitions of various reference materials measured using

mutual inductance detection. Using those known temperature points we can calibrate the CMN thermometer to get a precise measurement of the temperature across the entire range. In the following table (Table 1.1) we present the 13 reference points with the material, the transition temperature  $T_C$ , its transition width  $W_C$  (interval in which 80% of the transition occurs) and its relative uncertainty in percent  $U_{CT}$ .

<b>Material</b>	<b><math>T_C</math> (mK)</b>	<b><math>W_C</math> (mK)</b>	<b><math>U_{CT}</math> (%)</b>
W	14.41	0.5	0.78
Be	20.60	0.3	0.47
Ir <sub>80</sub> Rh <sub>20</sub>	35.24	1.0	0.73
Ir <sub>92</sub> Rh <sub>08</sub>	65.97	1.1	0.34
Ir	92.73	1.3	0.30
AuAl <sub>2</sub>	155.28	0.7	0.12
AuIn <sub>2</sub>	207.68	0.9	0.14
Cd	515.57	1.0	0.20
Zn	848.66	2.1	0.06
Al	1182	1.2	0.14
In	3418	<3	0.18
V	4925	<23	0.17
Pb	7205	<6	0.12

Table 1.1: Overview of the calibration data of SRD1000 [7].

## Chapter 2

# Experimental details

### 2.1 Thermometers design

In this section we present the design of the two types of thermometers that have been built for calibration. We got 100 resistors from "Distrelec" for about 5 euros. These thick film resistors have a room temperature resistance of  $2.2k\Omega$ , one can find more specifications in the "Distrelec" website (product code: 71 55 96) [8]. The  $RuO_2$ -based resistor has to be mounted on a support for various reasons. First to improve its mechanical resistance, but more importantly, to be able to easily attach it where it is needed. Also it is important to ensure a good thermal contact between the resistor and the element that has to be measured. It is known that at very low temperatures, the thermal conductivity of most of materials becomes marginal, there are no phonons to carry energy. It is then important to choose the material of the support carefully. For our thermometers we will use oxygen-free high thermal conductivity (OFHC) copper. It is a commercially available copper, widely used in cryogenics, with a 99,99% of purity that have been electrolytically refined to reduce the level of oxygen to 0.001% or below. Using OFHC copper is advantageous as compared to copper of a similar purity, the thermal conductivity is much higher. We also get a high impact strength and good creep resistance. To further improve the thermal coupling of the resistor we remove the protective black wax with a razor blade, bringing the resistive element closer to the copper. When mounting the resistor on the supports, they will be face down to maximize the contact within the resistor and the holder, a thin cigarette paper covered with low temperature GE varnish will have to be placed between the thermometer and the copper support to avoid short-circuits. In the following picture (Fig. 2.1) we show the resistor before and after removing the protective wax. The white part is only the substrate, the resistor itself is the green paste observed in the right thermometer. Before installing the thermometers, we carefully polish the contact surfaces of the copper pieces to improve the thermal contact. It is important to perform the polishing putting the smallest possible pressure on it, otherwise we will remove too much material from the edges, and end-up with a slightly convex surface.



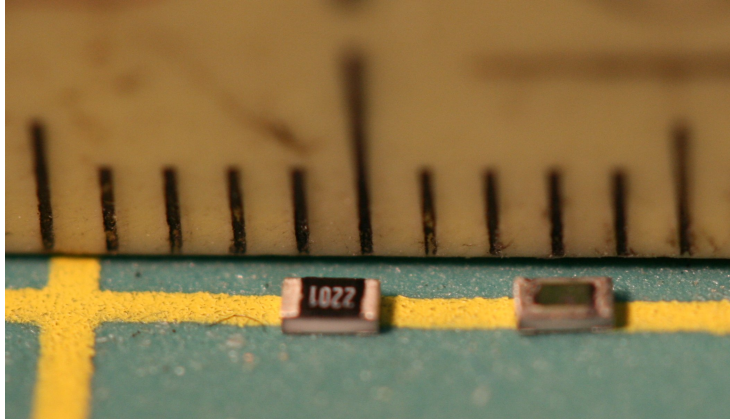

Figure 2.1: Picture of the  $RuO_2$  resistors before (left) and after (right) removing the protective black wax.

When considering the design of a thermometer holder, there are other features apart from the material that have to be taken in account. An important one is the size of the support, if we build a big support it will have a higher heat capacity and its response to changes in temperature will be slower. It is also advantageous to have a small size to reduce the induced eddy currents in the holder whenever a magnetic field is ramped. The induced current, which is proportional to the surface area perpendicular to the variable field, will dissipate heat in the thermometer holder. As we mentioned before we want to have a good thermal contact with the medium, but there is not only the direct contact with the resistor to take in account, as actually the resistor is primarily thermalised through the connector cables. These cables have to be connected to the electronics outside the fridge, there is a big gradient of temperature along all the connection, to avoid to put heat from the outside they are thermalised in the different stages of DR. To ensure that we measure the temperature of the resistor we have to make good thermal contact within the cables and the support. This thermal contact is usually done by wrapping the connectors around a rod-shaped part of the support. The resistors are connected by soldering two copper cables ( $200\mu m$  diameter) which are twisted together. The connector is a four pin connector in a 4 wires configuration (1-2 and 3-4 pins have a shortcut), we want to avoid measuring the resistance of the upper wires.

We decided to implement two different support designs, one where we prioritize the good thermal response by minimizing the size of the support (micro), and one where we prioritize an easy attachment of the thermometer to M3 threaded holes (small). In the figure 2.2 we present the drawings of both designs. Both are kept very small for the reasons mentioned above, the *Small Thermometer* (ST) has a total length of 16 mm and the *Micro Thermometer* (MT) has a length of only 6 mm. Both supports have a rectangular pit of  $3 \times 2$  mm with a depth of 1 mm to accommodate the resistor. The ST has a hole where it can be attached in with an M3 screw. It also has a rod, the connector cables are wrapped around the first half, and the second half is threaded with an M3 thread to be able to screw the thermometer directly into a copper plate. We use *Stycast W19* (transparent low temperature glue), specially conceived to glue solenoids, to protect the cables wrapped around the rod. Finally we also use *Stycast 2850 FT* (black), with good thermal conductance and low coefficient of thermal expansion, to cover the resistor and attach a washer on the top of the round hole. The goal is to protect

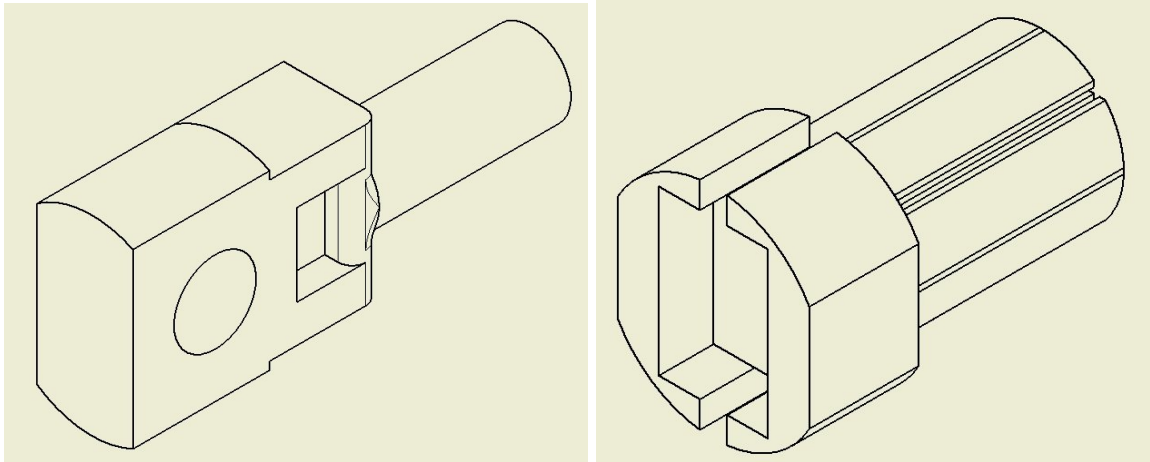

Figure 2.2: Drawing of the thermometers supports, Small (left) and Micro (right). Their respective length is 16 mm (small) and 6 mm (micro).

the resistor when the thermometer is screwed down. The MT has no holes or threaded rods to attach it, it is designed to be glued on a surface using low temperature varnish. As one can see (Fig. 2.2), there are two trenches where the two connectors leaving the resistor can pass through and then be wrapped around a rod. The rod is cut into rectangular patterned trenches, the goal is to minimize the effect of magnetic field induced Eddy currents by reducing the available surface. Once the thermometer is mounted, we deep it in a cylindrical bath of *Stycast W19* to ensure its mechanical resistance. Finally the top part (where the resistor is) is polished until we get a flat copper surface (clean of stycast). In the following picture (Fig. 2.3) we show the picture of two thermometers of each type. We built 5 of the ST and 6 of the MT, unfortunately 2 of the MT broke before the calibration process. It is also unfortunate that with the polishing of the top part of the MT, some of the solder on the resistors has been exposed, precautions must be taken to avoid short circuits.

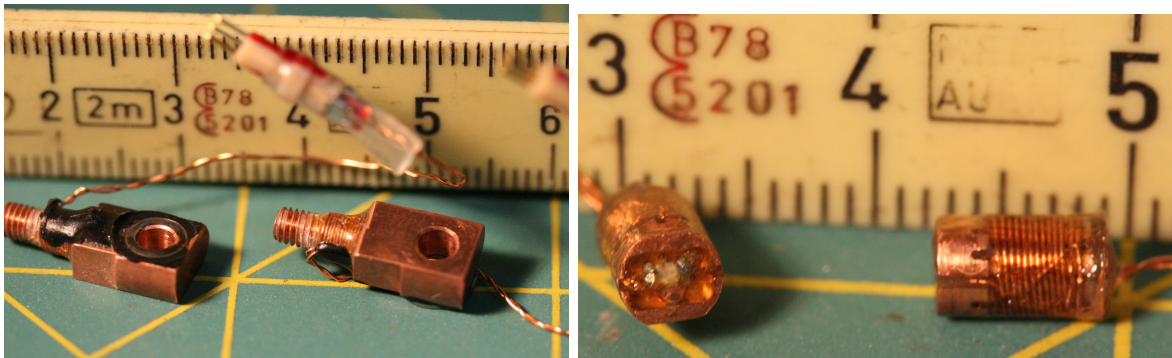

Figure 2.3: Picture of the thermometers, small (left) and Micro (right).

Once the thermometers are built, we cycle them 100 times to low temperature for the reasons mentioned in the introduction. We dip them a few seconds in liquid nitrogen, then we leave them at room temperature until they warm up again. It is important that we don't

heat them higher than 80 °C, we risk to re-annealing the thermometer paste (if it does happen one should restart the cycling from start). Finally they are mounted on the MC of the fridge and connected to a Lakeshore 370 that is able to read resistances in different channels using a 4 wire configuration. We use a small excitation ( $20\mu V$ ) to avoid heating the resistor while reading them. The data is logged in a computer

## 2.2 Temperature scans

Here we present a brief explanation of how we get the values of the resistance of our thermometers at different temperatures. The main idea is that we perform temperature scans while we record simultaneously, the data from the SRD and CMN thermometers, and the resistance of our  $RuO_2$  thermometers. In the introduction we had explained the basics of the DR and, although its principle seem quite straightforward, its practical operation may be problematic. The way of doing the temperature scans is, going first to the base temperature of the fridge (around  $7.5mK$  for our fridge), and then setting a temperature scan in the temperature controller to higher temperatures by heating the MC. The process can be repeated in the other direction. The temperature control is ensured by the closed PID loop of a Lakeshore 370 connected to the MC heater and the MC thermometer (a  $RuO_2$  thermometer previously on the DR and calibrated). Depending on the temperature range and the scan speed, the PID values may have to be optimized to get a better stability. For each set of thermometers we perform temperatures scans in 3 different regions.

First a normal temperature scan from base temperature to about  $740mK$  at a rate of  $1mK/min$ . This scan is quite easy to perform, we just have to adjust the heater range as the cooling power of the fridge changes. At low temperatures it might be too high and lead to instabilities, and if it is not high enough we may not achieve the desired temperature. A good value of the heater range may be  $1mA$  of current excitation. One of the main limitations of this scan is the that the scan is too fast to ensure a good thermalisation at very low T. Another one is that in the high temperature range, the phase separation in the MC become weaker, and the cooling power of the fridge becomes unstable, leading to fast oscillations of the temperature.

To get higher temperatures we collect all the helium mixture from the fridge to the storage dump and then condense just 10% of it. In this low mixture concentration regime we can get up to  $10K$  and down to about  $700mK$ . For the temperature control we perform as before but this time we use a higher heater range ( $10mA$ ). In this case the low temperature limitation is due to the small amount of mixture. As we get closer to  $10K$ , we observe that the temperature is very unstable, in this regime the amount of mixture condensed is very variable and so is the cooling power.

Finally we perform a third scan in the very low temperature regime ( from base temperature to  $40 - 100mK$ ) with a very slow scan rate. As the range is smaller, we can perform a scan with a rate of about  $0.12mK/s$  in a reasonable timescale. The goal is to have very precise measurements. The principle is the same as for the first scan.

# Chapter 3

## Calibration and discussions

### 3.1 Calibration

The goal of this project is to obtain a calibration curve for each thermometer, *i.e.* a set of points (about 100) giving the resistance *versus* temperature within the desired temperature range. It will also be important to know the reliability of the measured temperatures. As mentioned in the experimental part, the data is obtained by performing different temperature scans while logging simultaneously, the thermometers resistance, and the SRD and CMN thermometers. All the data treatment will be performed using "MatLab" software.

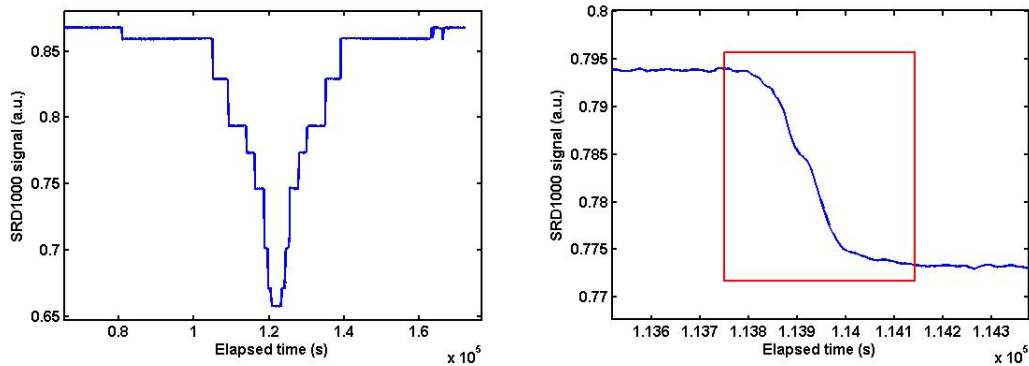

Figure 3.1: SRD signal *versus* time elapsed, in a temperature scan from  $740mK$  to base temperature and back up again to  $740mK$  (left). Close-up of one of the superconductive transitions (Iridium,  $92.73mK$ ) (right).

The first step consists of calibrating the CMN thermometer, it will allow us to know with a good precision the temperature at each moment. As for each temperature scan the conditions are slightly changed, we re-calibrate the CMN thermometer. In figure 3.1, we show the data obtained from the SRD thermometer in one of the temperature scans ( $740mK$  to base temperature and up again to  $740mK$ ) *versus* the elapsed time. We also show the detail of one of the superconductive transitions (Iridium,  $92.73mK$ ). By identifying the time segment (X values of the red rectangle in figure 3.1) corresponding to each superconductive transition, we know with a very high accuracy that within these two time points, the temperature of the MC plate was very close to the corresponding transition temperature. Then we just need to

extract the mean value of the CMN thermometer within this time range to have a value of the CMN signal at this transition temperature. To have a quantitative measure of the error of the measure, we will also extract the standard deviation of the CMN signal within this time range, if there are some temperature fluctuations, this will considerably increase the standard deviation, giving as wanted the information that this measure was probably not very accurate. In the following graph (Fig. 3.2) we present the signal of the CMN thermometer in the same temperature scan as in the previous graph (Fig. 3.1). One can see, as predicted by the theory, that the signal diverges as we get close to  $0K$ , as expected from a  $1/T$  behavior.

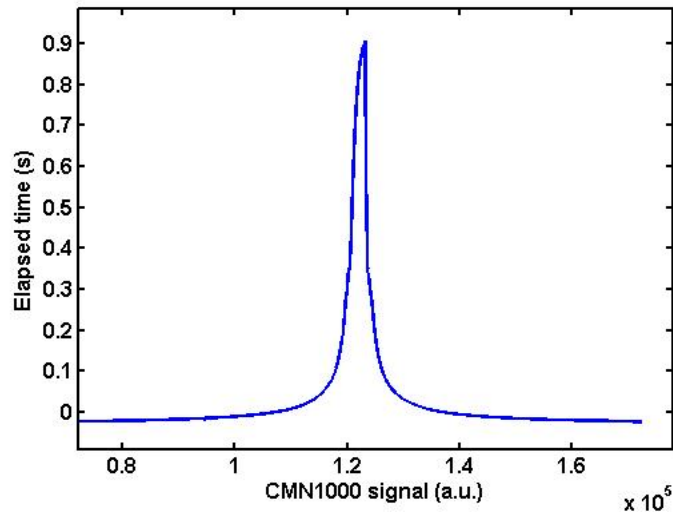

Figure 3.2: CMN signal versus time elapsed, in a temperature scan from  $740mK$  to base temperature and back up again to  $740mK$ .

Once we have a table with all the fix temperature points with its CMN value and its error we can proceed to calibrate the CMN thermometer. To do so we use the "spec1d" package from "MatLab". We fit the "Curie-Weiss" law (Eq. 1.1) to the values of the table. Inverting the equation and applying it to the CMN data, we are able to get a precise measure of the temperature for each time point. Finally we take 100 points logarithmically distributed in temperature and get the resistance of each of the  $RuO_2$  thermometers. By repeating this process for the 3 temperature scan ranges we are able to get resistance *versus* temperature points within the full calibration range for all the thermometers. In the following graph (Fig. 3.3) we show the 300 points obtained for the ST number 2 (ST2). We can see that the middle and high temperature calibration have a good matching, whereas the low temperature scan seems quite different. The discussions about the possible reasons of this mismatching will be discussed in a later section of this chapter.

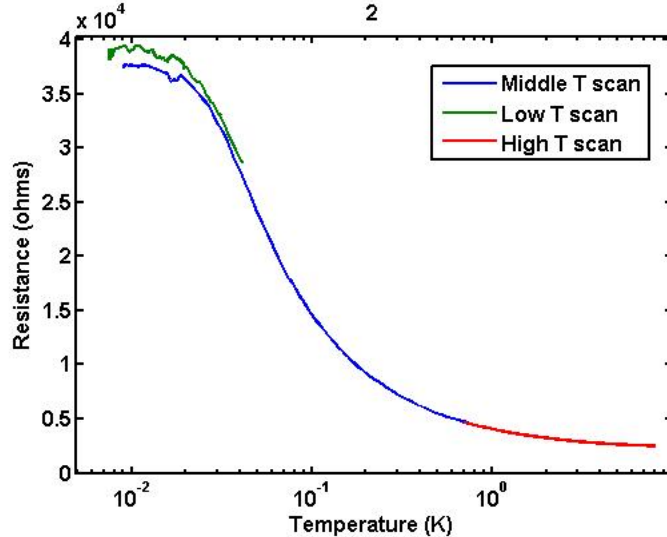

Figure 3.3: Preliminary calibration of the ST 2 thermometer for each of the 3 temperature scans.

Even neglecting the low temperature scan one can see that there are still some fluctuations in the calibrated points. The way this preliminary calibration is done, doesn't ensure that we didn't take points corresponding to moments where the temperature was stable and all the system at the same temperature. To have a better calibration we fit a phenomenological equation (Eq. 3.1) to the points obtained in the preliminary calibration.

$$\log(1/T) = \sum_{n=0}^5 a_n \cdot (\log(R - R_{300K}))^n \quad (3.1)$$

Where  $T$  is the temperature,  $a_n$  are 6 fitting parameters,  $R$  is the resistance of the thermometer in  $k\Omega$ , and  $R_{300K}$  is the resistance of the thermometer at room temperature ( $2.2k\Omega$ ). This equation is not based on theoretical reasons, it is a phenomenological equation that is largely used for resistor thermometers calibrations [9]. For the first set of thermometers (ST) we will just use 200 points corresponding to the middle and high temperature scan. For the second set (MT), there is no overlap of the temperature scans, so we will use all 300 pre-calibration points. In the following graph (Fig. 3.4) we show the fitting of the ST number 1 (ST1). As we notice, the lower temperature part doesn't follow the expected trend, the resistance saturate at low-T. To optimize the fit we have to remove the low temperature points for the calculation. It is then obvious that our calibration will have a lower limit of temperature validity considerably above the base temperature of the fridge. Despite those problems we can see that the fitting is considerably good for temperatures above  $30mK$ .

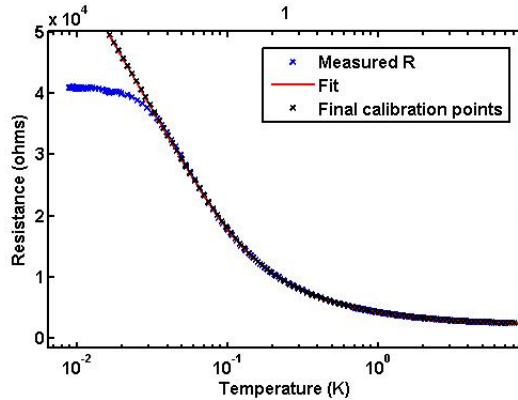

Figure 3.4: Fitting curve of the ST1 thermometer.

To get the final calibration points we select 100 points logarithmically distributed in temperature and using the fitting values we get their resistance. By doing the same full process with all the thermometers we obtain the desired calibration points. To know the reliability of the calibration we compute the difference between the temperature calculated with the calibration points and the actual temperature given by the measured points. As an example, we plot in the following graph (Fig. 3.5) the definitive calibration points and their relative error in the estimated temperature for the ST1. We can see that above  $30mK$  the relative error remains below a 5%, under that temperature the relative error diverges. The exact same trend is observed for all the thermometers, the diverging temperature is in a range between 30 and 40  $mK$ . We can then say that our calibration points are valid within a range of 40  $mK$  to 7.5  $K$ . The calibration points for each thermometer and its corresponding error curve is available in the google account of the LQM lab ([vittozz.lqm@gmail.com](mailto:vittozz.lqm@gmail.com)), in the google drive folder "New Thermometers".

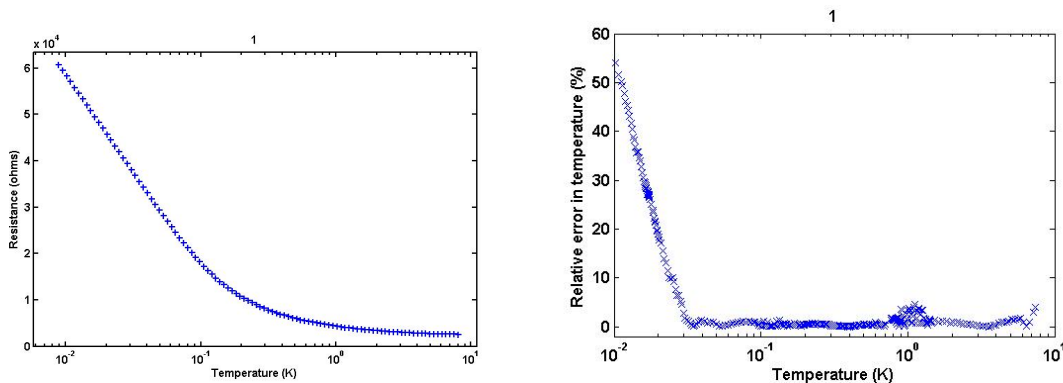

Figure 3.5: Calibration points for the ST1 thermometer(left). Relative error (in %) of the estimated temperature using the calibration curve (right).

It could be argued that using more terms in the equation (3.1), one could also have a better fit in the very low temperature range. Although this is true, we are not interested in increasing the accuracy of the calibration in that range at the expense of complicating the calibration equation and losing precision in the other domain. Moreover, as we already observed and

will discuss in the next section, the reproducibility of the resistance is not ensured below a temperature considerably above  $40mK$ . It is then not worth to force the fitting to match the actual resistance in the very low T range.

### 3.2 Very low temperature range

In this section we want to discuss briefly about the possible reasons of the mismatching of the resistance *versus* temperature curve at the lower temperature scan. The most evident reason would be that given the fact that this low temperature scan was performed at a lower scan rate, the system was better thermalised and the results have a better accuracy. If this hypothesis would be true, we should observe the same trend in the mismatching, *i.e.* all the low temperature scan curves should be either over, either under, the middle range calibration curve. Unfortunately, as we can observe in figure 3.6 showing the calibration curves of ST1, ST3, ST4 and ST5 for low temperatures, there is not a generalized trend. As the data is extracted from exactly the same temperature scan (simultaneously), we can confirm that this mismatching is not purely due to bad thermalisation.

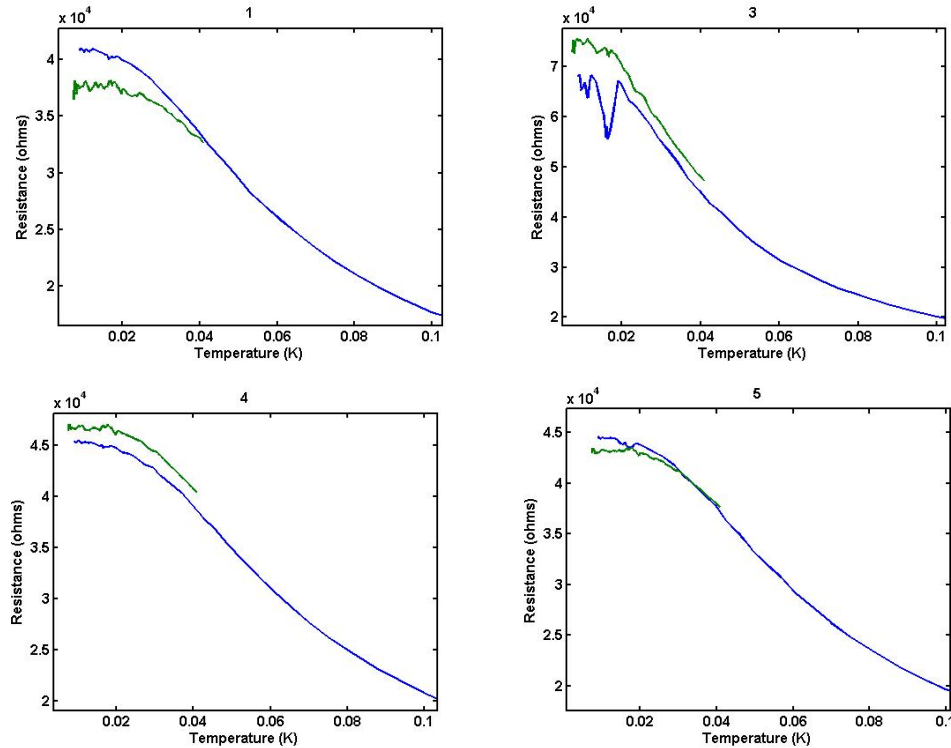

Figure 3.6: Zoom of the calibration curves to compare the very low temperature calibration (green) with the middle temperature calibration (blue) of the thermometers, ST1 (1), ST3 (3), ST4 (4) and ST5 (5).

Another explanation would be an intrinsic glass type behavior (*i.e.* an hysteresis of the resistance while ramping the temperature) of the  $RuO_2$  thermometer below a certain temperature. It would be interesting to realize, in a further study, consecutive temperature scans within the same cool-down to verify or challenge this hypothesis.



The three temperature scans were performed in the same cool-down, first the middle one, then we went up to  $10K$  for the high temperature scan, and finally we performed the very low temperature scan. As a last possibility it could be that the temperature cycling with the liquid nitrogen was not good enough, at  $10K$  there would be enough phonons to create permanent deformations in the resistor before going back again to the base temperature, leading to small changes in the resistance. The question of the validity of the calibration through different cooldowns will be generally discussed in the next section

### 3.3 Reproducibility

#### 3.3.1 Within the same thermometer

In this section we attempt to gain a quantitative idea of the reproducibility (*i.e.* the same behavior) of the thermometers within different cool-downs and within the same batch. We start by analyzing the data of the thermometer ST1 obtained during the calibration of the second type of thermometers (Micro). These corresponds to a different cool-down with the fridge having been at room temperature between measurements. Performing the same data treatment as in the "calibration" section, we can obtain a calibration curve of ST1 from a different cool-down. In figure 3.7, we present the two calibration curves and the discrepancy in the calculated temperature using the two calibration curves (also available on [vittozz.lqm@gmail.com](mailto:vittozz.lqm@gmail.com)).

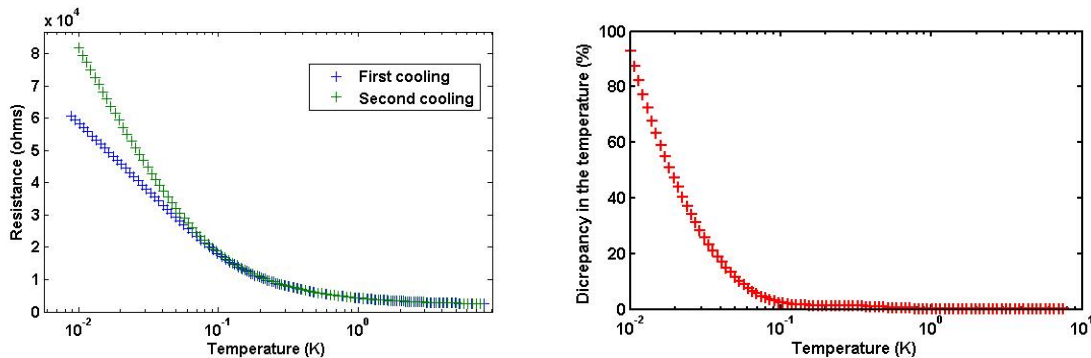

Figure 3.7: Calibration points for the ST1 thermometer obtained in two different cool-downs (left). Relative discrepancy (in %) of the estimated temperature using the two calibration curves (right).

We observe that the discrepancy in the calculated temperature is within a very acceptable range over  $80mK$ , and then diverges exponentially under that temperature. This results can't definitively say if the low temperature mismatching is due to a hysteresis of the resistance at very low temperatures, or due to a bad temperature cycling. More measurement should be done, in their paper, RG Goodrich *et. al.* [6], ensured the reproducibility of the measured temperature by cycling the thermometers with successive cool-downs to liquid nitrogen and liquid helium temperatures. We can't really know if this treatment should ensure the stability of the thermometers below liquid helium temperatures, because they don't measure it. If after extended measurements this "hysteresis" behavior is confirmed, it would be interesting to do the same experiment but going to liquid helium temperatures or even below (with a top loaded

DR) in the temperature cycling. Although this measurement doesn't give a definitive answer to the questions above mentioned, and just one thermometer has been tested, it is very likely correct to consider that the precision of our thermometers is better than a 5% in temperature in the range between  $90mK$  and  $7.5K$ .

### 3.3.2 Within the batch

As a final comment, we compare the calibration curves of the 5 ST thermometers. As they all come from the same batch, if their calibration curve is close enough it would be possible to use all the 85 remaining resistors from this batch without calibrating them, just using a standard calibration curve. In the following graph (Fig. 3.8) we present all the calibration curves for the ST thermometers, and the absolute value of the discrepancy of calculated temperatures for the other ST thermometers compared to ST1.

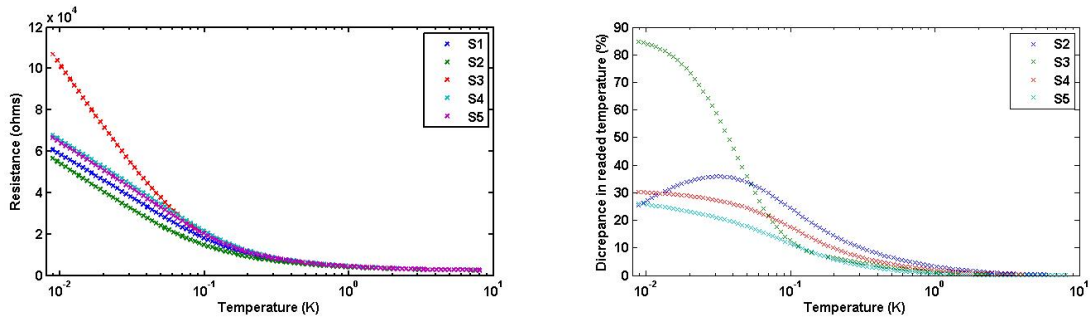

Figure 3.8: Calibration points for the ST thermometers obtained in the first cool-down(left). Absolute value of the relative discrepancy (in %) of the estimated temperature using their own calibration curve, or the calibration curve of ST1 (right).

In the range of temperatures from  $1K$  to  $7.5K$ , the discrepancy in the measured temperature seems to be acceptable, whereas for lower temperatures ( $90mK$  to  $1K$ ), the discrepancy raises almost to 30%. In the lowest temperature range, the discrepancy becomes even higher, but it is not a problem due to the observation done in the previous subsection, the reliability of the temperature in that temperature range is anyway compromised. The discussion is then if it is worth to calibrate each thermometer from the batch just to have a better precision in the temperature range from  $90mK$  and  $1K$ . There is no a definitive answer, it depends on the needs of the experiment and the time available. For very precise measurements in the range of hundreds of  $mK$  it would be useful to use the calibrated thermometers. For experiments where the precision of the measured temperature is not very important, or performed in the range of temperatures of few Kelvins, we may use any resistor of the batch with a standard calibration.

# Conclusion

In this report we have seen a method to build cheap thermometers for dilution refrigerator thermometry from  $RuO_2$ -based resistors. Although the calibration is not accurate below a relatively high temperature, compared to the base temperature of the DR, we have built good precision thermometers in a wide temperature range ( $90mK$  to  $7.5K$ ). For a higher precision in lower temperatures, we can always use the SRD and CMN thermometers. It would also be interesting to buy  $RuO_2$ -based resistors with other room temperature ranges and check their low temperature behavior (cutoff temperature and high T sensitivity).

We also have noticed a significant variance of the resistance, upon different cool-downs, within the same resistor below  $90mK$ . It would be interesting to perform other experiments to know if it is an intrinsic behavior of the  $RuO_2$ -based resistors, or if it is due to some experimental error. If it is an intrinsic behavior, we may consider to change either the type or the nature of the resistor used for the very low temperature measurements.

Finally, there are some changes in the design that could considerably improve the thermometers. The most critical ones are the MT, as we mentioned two of them already broke. The way the connector leaves the Stycast cover (perpendicular to the surface), puts a lot of stress in that precise point of the connector, and makes it easy to brake. Also due to its extremely small size we have a very small surface to ensure a good thermal contact.

This report gives us, not only 9 calibrated thermometers, but also a valuable experience to build and calibrate further thermometers.

# Bibliography

- [1] Erkki Thuneberg. Phase diagram for the mixture of helium isotopes. <http://ltd.tkk.fi/research/theory/mixture.html>, August 2003.
- [2] G Frossati. Obtaining ultralow temperatures by dilution of  $^3\text{He}$  into  $^4\text{He}$ . *Le Journal de Physique Colloques*, 39(C6):C6–1578, 1978.
- [3] Craig N and Lester T. Hitchhikers guide to the dilution refrigerator, 2004.
- [4] RW Willekers, F Mathu, HC Meijer, and H Postma. Thick film thermometers with predictable r-t characteristics and very low magnetoresistance below 1 k. *Cryogenics*, 30(4):351–355, 1990.
- [5] Dariusz et. al. Zak. Implementation of  $\text{RuO}_2$ -glass based thick film resistors in cryogenic thermometry. *Measurement Science and Technology*, 17(1):22, 2006.
- [6] RG Goodrich, Donavan Hall, Eric Palm, and Tim Murphy. Magnetoresistance below 1k and temperature cycling of ruthenium oxide–bismuth ruthenate cryogenic thermometers. *Cryogenics*, 38(2):221–225, 1998.
- [7] Hightech Developement Leiden. Srd1000 measurement systems. <http://hdleiden.home.xs4all.nl/srd1000/>, december 2010.
- [8] <https://www.distrelec.ch/resistors-smd-1-0603/vishay/d11-crcw0603/en>.
- [9] Julian Piatek. *Ultra Low Temperature Susceptometer and Magnetometer Study of the Spin Glass Series  $\text{LiHo}_x\text{Er}_{1-x}\text{F}_4$* . PhD thesis, EPFL, 2012.